



**Distribution System Options Report:**

**Modification works at Richborough and Canterbury South 132 kV Substations  
and of the 132 kV distribution network.**

**In support of the Richborough Connection Project**

UK Power Networks  
237 Southwark Bridge Road  
London  
SE1 6NP

National Grid  
National Grid House  
Warwick Technology Park  
Gallows Hill  
Warwick  
CV34 6DA

Issue 1.0 February, 2015

<b>Table of Contents</b>	<b>Page</b>
1. Introduction.....	2
2. The Need for infrastructure modifications on The UKPN Network. ....	6
3. Options to maintain the existing system security and network flexibility. ....	10
4. Overview of Options Appraisal Methodology .....	15
5. Summary of options appraisal.....	16
6. Identification of the preferred option.....	20
Glossary .....	21

## **1. Introduction**

- 1.1. This report has been prepared jointly by UK Power Networks (South East) Ltd. (UK Power Networks) and National Grid Electricity Transmission Limited (National Grid).
  
- 1.2. This report will form background information in support of an application for an Order granting Development Consent (DCO). Subject to consultation, these works will be as part of the cumulative assessment within the DCO for the Richborough Connection Project which will be submitted by National Grid to the Planning Inspectorate (PINS) in autumn 2015.
  
- 1.3. To accommodate the connection of a new HVDC Interconnector at Richborough, Kent, a new 400kV transmission connection is proposed between Richborough and Canterbury North substations, as identified in the Richborough Connection Project Strategic Options Report<sup>1</sup>

---

<sup>1</sup> Richborough Connection Project Strategic Options Report:

- 1.4. The preferred route, as identified in the Richborough Connection Project Preferred Connection Option and Route Corridor Report<sup>2</sup>, for this new transmission connection broadly follows the route of an existing 132kV overhead line that connects the Richborough and Canterbury South 132 kV substations. The preferred route corridor is illustrated in Figure 1.1 below.
- 1.5. This 132kV overhead line is operated by UK Power Networks (South East) Limited (UK Power Networks) and is proposed to be removed between Richborough and Canterbury South substations as part of the Richborough Connection project. The removal of the existing 132 kV overhead line is consistent with the National Grid Stakeholder, Community and Amenity Policy, National Policies EN 1 & EN 5, and confirmed following the consultations on the project held during Summer 2013.

---

<http://richboroughconnection.co.uk/assets/downloads/Preferred%20Connection%20Option%20and%20Route%20Corridor%20Report%20FINAL%20Nov%202013.pdf>

<sup>2</sup> Richborough Connection Project Preferred Connection Option and Route Corridor Report:

<http://richboroughconnection.co.uk/assets/downloads/Preferred%20Connection%20Option%20and%20Route%20Corridor%20Report%20FINAL%20Nov%202013.pdf>

**Figure 1.1 Preferred Route Corridor for the Richborough Connection Project**

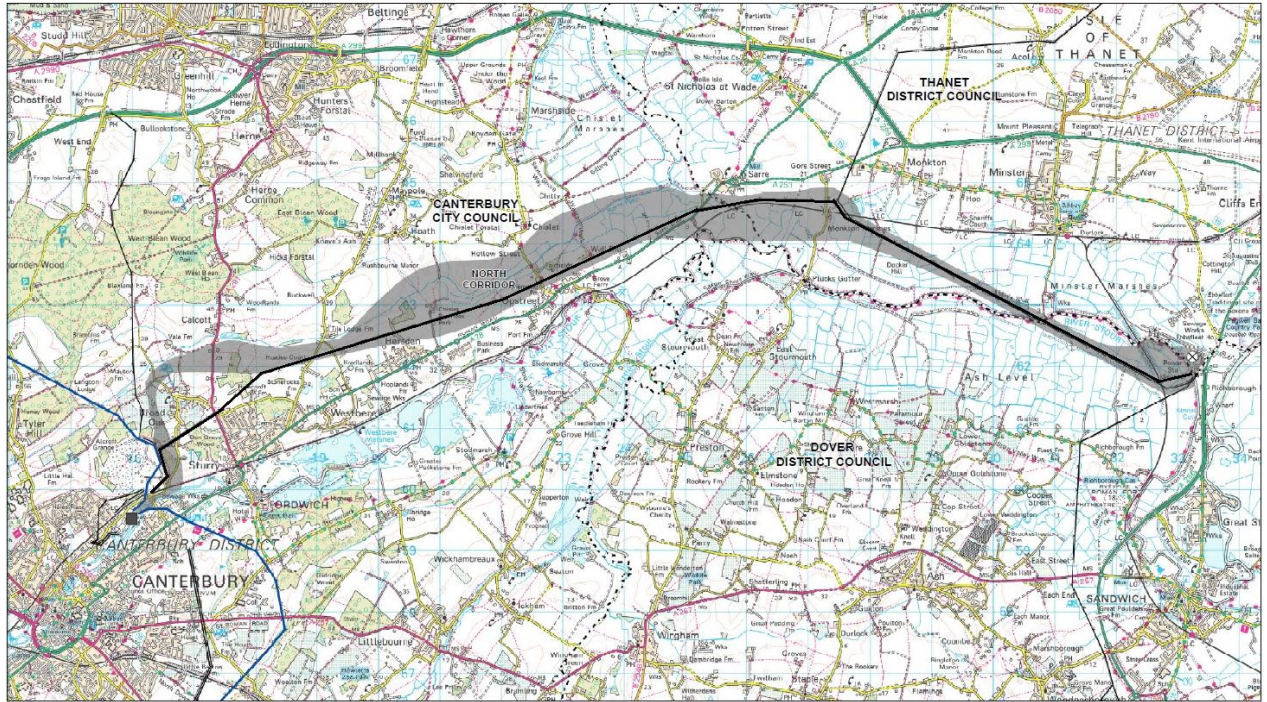

- 1.6. This Distribution System Options Report (The Report) has been produced by UK Power Networks and National Grid which looks at the options to maintain the security, resilience and operational flexibility of the 132 kV distribution system as a consequence of the proposal to remove the UK Power Networks, Richborough to Canterbury South 132kV overhead line.
- 1.7. This report looks at the infrastructure modifications that are required to maintain the local distribution system's security of supply for customers at existing levels as a result of the removal of the 132kV line from Richborough to Canterbury as part of the Richborough Connection Project.

1.8. The structure of this document is as follows:

- Section 1 provides an introduction;
- Section 2 provides background on the need for the modification works that are required;
- Section 3 outlines options;
- Section 4 provides details of the option appraisal methodology;
- Section 5 provides a summary of the option appraisal;
- Section 6 confirms the preferred technical and environmental option.

## **2. The Need for infrastructure modifications on The UKPN Network.**

- 2.1 The electricity system is made up of networks which operate at different voltage levels. Transmission networks, which in England and Wales operate at voltages of 400kV and 275kV, are used for the bulk transfer of power from generation to distribution networks. This is primarily to facilitate higher power transfers and to reduce the amount of power lost during the transportation process because losses are reduced at higher voltages.
- 2.2 Distribution networks, in contrast, are mainly concerned with the delivery of power to consumers at lower voltages: 132kV, 66kV, 33kV and below. Distribution networks typically provide electricity to major conurbations through a radial network of circuits operating at reducing voltage levels and power carrying capacity.
- 2.3 The connection of transmission and distribution networks occurs at Grid Supply Points (GSP). These are typically substations where power is transformed from 400kV or 275kV to 132kV, 66kV or 33kV for onward distribution to consumers.
- 2.4 Bulk Supply Point (BSP) substations operate at 132kV and 66kV and provide a distribution hub where power is transformed to voltages ranging from 66-33kV and below for onward distribution to local towns, villages, farms and industry
- 2.5 Figure 2.1 below indicates the existing UK Power Networks network surrounding Richborough and Canterbury.

**Figure 2.1 The Existing UK Power Networks 132 kV network:**

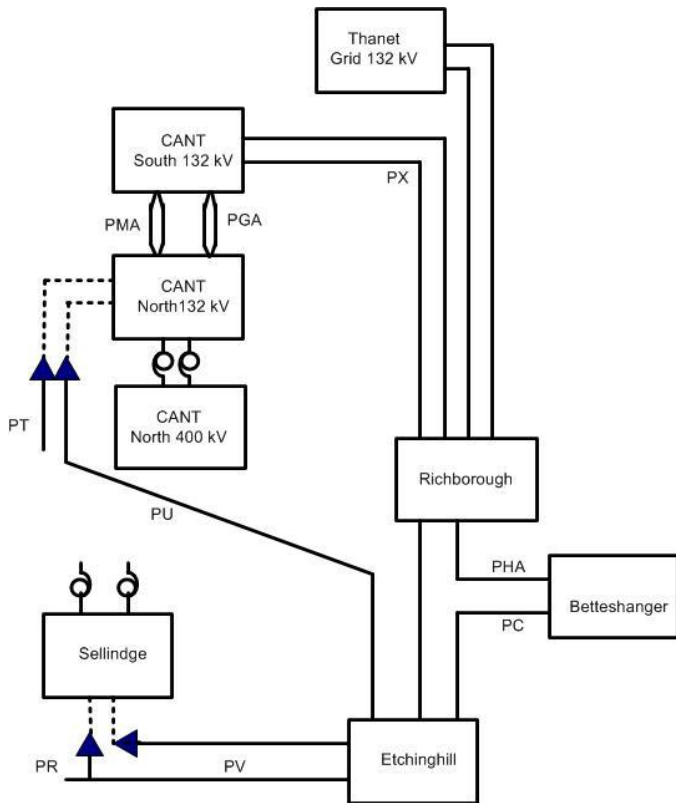

2.6 The UK Power Networks 132kV network in the Canterbury and Richborough area is currently served by two Grid Supply Point (GSP) connections to the 400 kV transmission system at Canterbury North and Sellindge. The 132 kV network serves Canterbury North and Richborough via circuits including:

- The double circuit overhead line route connecting Canterbury South to Richborough, known as the PX route;
- The single overhead line and underground cable Etchinghill to Canterbury North PU route.

2.7 Two 132 kV overhead line double circuits, the PGA & PMA routes, connecting between Canterbury North to Canterbury South are connected together at each end to form two single circuits (termed as 'Banked').

2.8 Thanet Offshore Wind is connected to Richborough 132kV with a capacity of 315MW. There is also additional generation of approximately 310 MW

embedded in the Distribution Network with a further 299 MW accepted for future connection. The present network configuration allows the generation to be maintained under planned and unplanned outage conditions with an export constraint applied to offshore wind generation connected at Thanet under certain network conditions.

2.9 The UKPN 132 kV network in the Canterbury & Richborough area is compliant with the requirements laid out in Engineering Recommendation P2/6 & presently operates as an interconnected group. This increases operational flexibility as well as allowing supplies to be maintained under planned and unplanned outage conditions at the National Grid interface points and on the majority of interconnected circuits.

2.10 The proposed removal of UK Power Networks's 132kV double circuit overhead line between Richborough and Canterbury South substations would reduce the level of network security of the UK Power Networks 132 kV network in the Canterbury area, such that it would not be compliant with P2/6.

2.11 The removal of the UK Power Networks 132 kV PX route would result in the following non-compliances:

- The existing Canterbury North – Sellindge Grid Supply Points (GSP) have a firm capacity of 276 MW each. Removal of the PX route would result in all of the group demand being supported by these GSPs. Demand is predicted by UK Power Networks to reach 672 MW by 2020. Therefore, assuming the demand is shared evenly, both GSPs would become non-compliant.
- A double circuit fault on the two banked circuits connecting Canterbury North to Canterbury South would result in all of the demand at Canterbury South being lost.

2.12 UK Power Networks must maintain compliance with Engineering Recommendation P2/6 and National Grid and UK Power Networks have agreed



to maintain the current level of capacity, flexibility & resilience of the electricity distribution system in these areas.

- 2.13 Therefore, options are needed to mitigate these non-compliances, which result from the removal of the UK Power Networks 132 kV PX route that connects Canterbury South to Richborough substations.
- 2.14 This report outlines the modification works required on the UK Power Networks network at Richborough and Canterbury and considers the options that are available. The report outlines the appraisal that has been completed to identify the preferred option and confirms the preferred option.
- 2.15 To identify potential options to enable the removal of the 132 kV Canterbury South to Richborough 132 kV overhead line circuit, a technical appraisal of available options was undertaken by UK Power Networks and National Grid.

### **3. Options to maintain the existing system security and network flexibility.**

- 3.1. Seven possible options were assessed in the original technical appraisal. Of these, four were rejected as not technically compliant, one option was discounted on the grounds of whilst initially compliant, it would become non compliant in the near future. Two technically compliant options, have been identified and brought forward for further consideration to select a preferred option.

#### *Options to Secure Demand in the Richborough Area*

##### **Option 1**

- 3.2. To enable the removal of the existing PX 132 kV route, construct a new 400/132 kV Grid Supply Point (GSP) at Richborough accommodated within the proposed new substation at Richborough. Option 1 is outlined in Figure 3.2

**Fig 3.2 The UK Power Networks 132 kV network: Option 1**

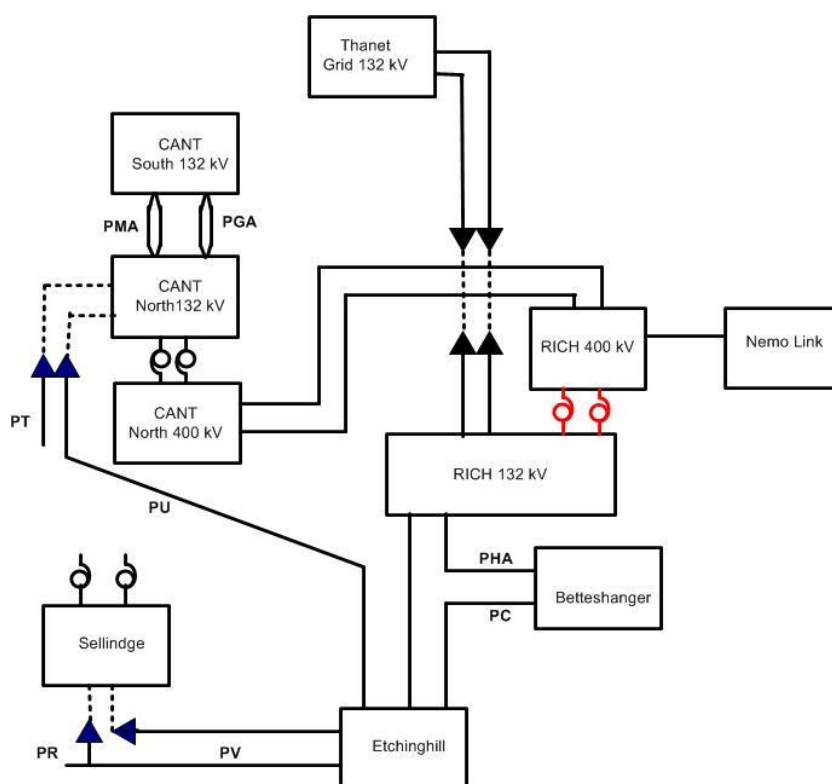

- 3.3. For this option the provision of one 400/132 kV Transformer was considered. This was discounted, as whilst initially compliant, this would result in the system eventually becoming non-compliant.
- 3.4. Whilst a single transformer can provide suitable rating to replace the existing PX double circuit route (105 MVA summer continuous rating) this would result in the UK Power Networks network becoming non-compliant before 2020 under summer conditions. This is in advance of when the existing 132kV network would otherwise become non-compliant.
- 3.5. Based on 2020 expected demand, with a planned outage of the new 400/132 kV Super Grid Transformer at Richborough, a fault on the existing 132 kV network would result in unacceptable overloads.
- 3.6. Provision of two 400/132 kV supergrid transformers would therefore be required to maintain compliance & existing resilience & flexibility of the UK Power Networks 132 kV network.
- 3.7. The two Super Grid Transformers would be accommodated as part of the proposed new 400 kV Richborough substation works and will be limited to the proposed consent with outline permission at the site of the former Richborough power station site

*Securing Demand at Canterbury South 132 kV Substation.*

- 3.8. The present configuration at Canterbury South consists of four 132 kV circuits feeding Canterbury South. Under planned and unplanned outage conditions demand can be maintained without interruption.
- 3.9. Following removal of the PX 132 kV route and construction of a new GSP at Richborough under Option 1, for the same conditions, all demand would be lost and cannot be supported via interconnection at lower voltages. To maintain system security at Canterbury South an additional 132 kV circuit needs to be connected.
- 3.10. UK Power Networks propose to provide this additional 132 kV circuit by diverting the existing PU circuit from Canterbury North, reconnecting it into Canterbury South. As shown below in Fig 3.3.

**Fig 3.3 Diversion of the PU 132 kV Route into Canterbury South**

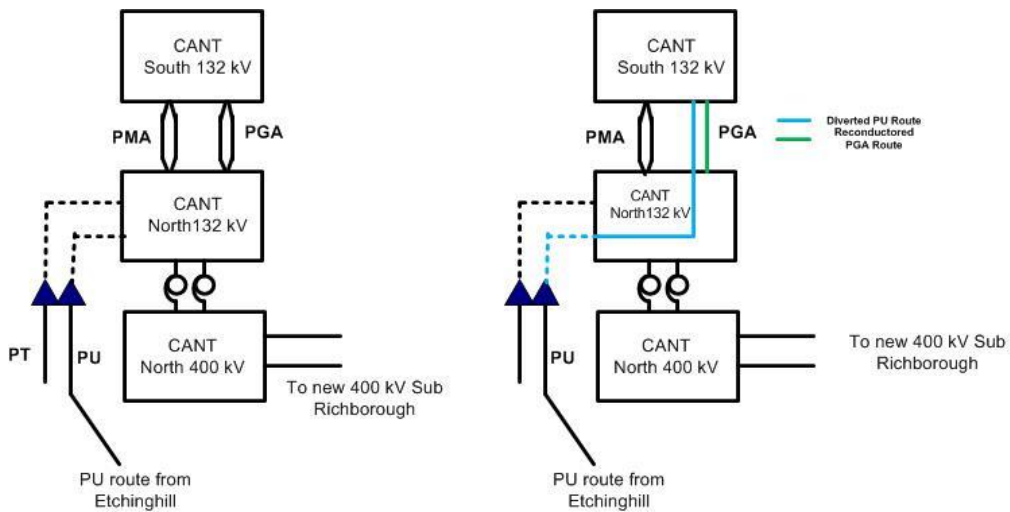

3.11. This will be achieved by:

- Reconfiguring the existing banked PGA 132 kV overhead line routes between Canterbury North and Canterbury South 132 kV substations, to form separate circuits;
- upgrading one circuit of the unbanked PGA circuits with a higher rated conductor;
- utilise the remaining PGA circuit to divert the PU route from Canterbury North into Canterbury South;
- construct a small disconnector compound between the existing PX and PGA terminal tower within UK Power Networks land ownership, outside of the operational area at Canterbury South.

3.12. UK Power Networks have confirmed that the reconfiguration of Canterbury North to achieve diversion of the PU route into Canterbury South is the most economic and efficient method to secure demand at Canterbury South. It can be built largely off-line without the need for extensive system outages, and minimises the level of modifications to existing equipment. UK Power Networks expect that required consents will be achieved within existing Permitted Development rights.

## Option 2

- 3.13. Replace the existing PX 132 kV overhead line route with an equivalent underground cable route of approximately 25 km length. Option 2 is outlined in Figure 3.5

**Fig 3.5 The UK Power Networks 132 kV Network: Option 2**

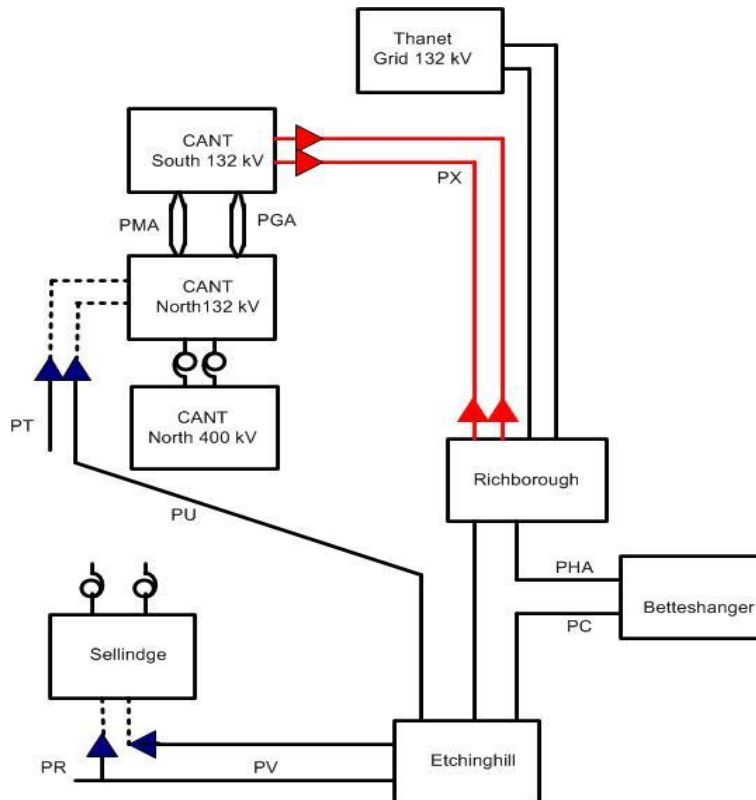

- 3.14. Option 2 maintains the existing resilience of the UK Power Networks 132 kV network and ensures compliance with P2/6 beyond the current RIIO regulatory period (RIIO ED1). This option also secures demand at Canterbury South without further modification.

#### **4. Overview of Options Appraisal Methodology**

- 4.1 Options appraisal considers relevant technical, environmental and socio-economic issues and the costs associated with each technical option. Analysis of these factors allows UK Power Networks and National Grid to assess which options best meet their various statutory and licence obligations.
- 4.2 UK Power Networks and National Grid will only propose to build new infrastructure where existing infrastructure cannot be technically or economically upgraded to meet system security standards and regulatory obligations. Where there is no viable existing upgrade option, UK Power Networks and National Grid will develop a solution (e.g. installation or construction of a new infrastructure) that seeks to achieve the best integration of their various duties and obligations as set out in Appendix 1.

#### **Technical Appraisal**

Section 3 explains that each technical option has been assessed initially to ensure that it meets the need to maintain existing levels of system security and flexibility and that the resultant transmission and distribution systems would comply with the standards set out in P2/6 and NETS SQSS.

## **Economic Appraisal**

- 4.3 Once the full scope of works associated with each option is identified, an estimate of the capital cost of that scope of works is made. For the specific new overhead line, underground AC cable, substations and transformers (SGTs) associated with each option, operational lifetime costs are then estimated.
- 4.4 Capital cost is an estimate of the cost of equipment and installation costs. These costs are provided in current financial year prices applicable at the time of publication of this Report. For the purposes of reviewing technical options, the cost estimates are based on generalised unit costs for the key elements of the option, reflecting recent contract values or manufacturers' or consultants' budget estimates. This is sufficient to allow a broad order of consistent costs to be established for the options, as necessary at the strategic level, and is not intended to provide a detailed cost for each option which can only be obtained at the detailed design stage.

## **Environmental Appraisal**

- 4.5 A high level appraisal of the environmental impacts for each of the technical options, (see Section 5 below), has considered environmental constraints of international and national importance. Features considered as potential environmental constraints to each technical option are presented in Table 5.1. This table summarises the findings at a high level of environmental constraints in relation to each option in considering the alternatives for the removal of the 132kV connection. This identifies potential environmental constraints and the need for further investigations where appropriate.

## **5. Summary of options appraisal**

The table below provides a summary of the key factors to be considered in appraising each of the connection options:



**Table 5.1: Options Summary**

Option	Technical	Environmental	Capital Cost
Option 1	<ul style="list-style-type: none"> <li>• Construct 2x 400/132kV Grid Supply Point connecting to the existing Richborough 132kV switchboard</li> <li>• Reconfigure Canterbury North and South substations, Unbank PGA Overhead line circuits, reconductoring 1 circuit.</li> <li>• Fully P2/6 compliant option.</li> <li>• Requires additional infrastructure to secure demand at Canterbury South</li> <li>• New GSP must be commissioned prior to removal of PX</li> </ul>	<ul style="list-style-type: none"> <li>• No significant temporary or permanent impacts to environmental receptors as works are limited to the proposed Richborough substation consented with outline permission at the site of the former Richborough power station site</li> <li>• Minor potential additional visual amenity impacts associated with the location of two SGT at the substation site, although this will be set within the context of a substation which will contain further substation equipment and plant including a building of</li> </ul>	<ul style="list-style-type: none"> <li>• Based on National Grid figures for GSP &amp; UK Power Networks Figures for PU Diversion works:</li> <li>• Tot. Estimated capital cost = £22m</li> </ul>

	overhead line Route.	approximately 15m in height	
Option 2	<p>Replace the existing PX overhead line route with a fully underground cable route, of approximately 25 km of 2 X Circuits, 2 cable sealing end compounds . –</p> <ul style="list-style-type: none"> <li>• Fully P2/6 compliant option</li> <li>• Secures demand at Canterbury South without additional infrastructure</li> <li>• Largely offline build with minimum system outages</li> <li>• Long construction period – approximately 50 months. (based on UK Power Networks figure of 2 months per km per working team)</li> </ul>	<ul style="list-style-type: none"> <li>• There is potential to encounter and which could significantly affect unknown buried archaeology.</li> <li>• Depending on the location of the route the installation of underground cables could affect ecological receptors particularly during construction of the cable</li> <li>• Resultant effects on landscape character and views would be temporary and land would be restored on completion.</li> <li>• There could be some minor negative localised effects associated with the removal of existing features including hedges and trees during construction. These effects could be mitigated by careful routeing to</li> </ul>	<ul style="list-style-type: none"> <li>• Based on UK Power Networks figures:</li> </ul> <p><b>Tot. Estimated capital cost = £38.5m</b></p>

		retain trees where possible, replanting hedges and or planting of new trees and shrubs.ght.	
--	--	---	--

## **6. Identification of the preferred option**

- 6.1. This Distribution System options report has summarised the need for infrastructure modifications to the UK Power Networks 132 kV network in the Richborough and Canterbury areas, outlined the changes required and considered the technical alternatives, environmental impact and estimated capital costs of the two compliant options for securing UK Power Networks demand following removal of the UK Power Networks PX overhead line double circuit.
- 6.2. Each of the options considered is compliant with technical standards.
- 6.3. The environmental appraisal concluded that there would be greater environmental effects associated with Option 2 in comparison to Option 1 in which two Super Grid Transformers would be sited within a new substation site which has already gained outline planning permission which includes for the two transformers. Canterbury North will be reconfigured within existing operational and ownership boundaries.
- 6.4. Given the scale and localised nature of works and their location socio-economic factors were not considered significant in this appraisal and have been scoped out.
- 6.5. Estimated capital cost has been considered as part of the appraisal of the two options. Visual impact has also been taken into account. The option that offers minimal changes in visual impact is the most economic and efficient option.
- 6.6. Either option would require to be planned and coordinated alongside the proposed works for the connection of Nemolink and completed prior to the full disconnection and removal of the existing PX 132 kV overhead line route.
- 6.7. Having regard to relevant statutory duties and all the factors considered as part of the appraisal process,. Option 1 has been identified as being economic, deliverable and having minimal impact. Under this option the UK Power Networks demand is secured via the provision of a new Grid Supply Point at Richborough and diversion works at Canterbury North and Canterbury South. Option 1 is identified as the preferred option. The preferred option will not result in any new circuits or substations being constructed.

## Glossary

<u>NETS</u> <u>SQSS</u>	National Electricity Transmission System Security and Quality of Supply Standard
kV	Kilovolt
MW	Megawatt
M	Metre
Km	Kilometre
CSE	Cable Sealing End
SEP	Sealing End Platform